

Haven

Users Manual



Thank you

Thank you for purchasing a Repose Haven rise recliner healthcare chair with unique air pressure cushions in the lower backrest, seat cushions and leg rest which enable high levels of pressure management care to be undertaken. With a choice of Tilt in Space mechanisms and coming in three sizes it offers an ideal solution for any healthcare environment.

To maximise the advantages of your chair please take the time to read these instructions carefully, as they contain essential information on set-up and operation of all key features, as well as upholstery care, important safety advice plus warranty and contact details. If for any reason you are unsure of anything, please contact your supplier immediately for further information. Please keep this manual safe for future reference.



Contents

Page	
4	What Our Expert Says
6	Important Safety Instructions
8	Accupak Rechargeable Battery System
10	20 Cycle Rechargeable Battery System
11	Basic Technical Checks
11	Recommended Quality Checks
12	Chair Delivery
12	Pressure Care Management
12	Weight Limits
13	Feature Functionality
18	Back Cushion Features
20	Seat and Leg Rest Cushion Features
22	Optional Accessories
23	Chair Dimensions
24	Fabrics
25	General Upholstery Care
26	Transport - Back Frame Removal
27	Warranty

What Our Expert Says

Who is this chair suitable for?

The Haven comes with unique air pressure cushioning in the lower back rest, seat cushion and leg rest with the ability to alter levels of air pressure. This allows for a truly personalised seating experience based on a user's specific needs with a focus on the person, their activities and the impact of their condition.

The air cushions work constantly to evenly distribute the user's weight ensuring that there are no pressure points that might restrict circulation. The high level of pressure relief is due to the air cushions constant movement and repositioning of pressure.

With a choice of Dual or Single Tilt in Space motors, the Haven is ideal for clients with changing and deteriorating neurological conditions and those who require assisted movement to reduce the problems of skin breakdown.

Where can the chair be used?

The chair is suitable for health and care environments including hospitals, hospices and care homes as well as domestic home environments. It is ideal for nursing home residents or clients being cared for at the end of their life.

What are the feature benefits?

The Tilt in Space

This allows the seat back angle to remain the same whilst the whole seating system is tilted backwards allowing the angle of the hips, knees and ankles to remain unaffected reducing shear and friction during this movement.

It also reduces the weight on the Ischial Tuberosities by redistributing the weight through the back. This feature can also help when transferring someone in a sling as it can support better pelvic positioning by using gravity to position the user in the back of the chair in the optimal position. Always engage lockable castors during transfers to aid chair stability.



A handwritten signature in black ink that reads "Kate Sheehan".

Kate Sheehan
Independent Occupational Therapist

Split contoured air cushion back

The back is divided into two distinct areas, the thoracic and lumbar part of the back being supported by a one cell air bag, providing a high level of pressure relief due to its constant movement and repositioning of pressure. The top head cushion is Dacron fibre filled and can be adjusted providing additional head support and comfort.

This back can be useful for anyone with limited ability to independently alter position, for example those who have suffered a stroke or with a brain injury, MND, spinal injury and palliative care. The Dacron has the ability to transfer heat which can make it very useful for groups who rely on regulated temperature such as MS.

Single air seat cushion

For those who currently have or who are at a high risk of pressure problems or sores and who have limited ability to change their position and relieve the pressure on their sacrum and buttocks.

Users need to have appropriate pelvic stability and core trunk strength to accommodate the air pressure changes and related movement in this single air cushion.

Leg rest air cushion

The single cell airbag provides consistent support across the whole of the thighs, back of the knees and calf and reduces the risk of pressure problems.

Full Chaise cover

The Haven benefits from a single, full seat cover. This chaise reduces the risk of pressure areas developing due to pinch points and shear and friction when the chair reclines.



Important Safety Instructions

The following instructions are for your own safety, the safety of others and to ensure that the chair is used correctly and in line with the warranty conditions.

Please ensure that:

- **YOU ALWAYS KEEP THESE INSTRUCTIONS SAFE** as you will need them for reference purposes.
- **ALL CARERS AND ATTENDANTS** are trained in the full use of the chair and are qualified to provide advice on the pressure management and postural care options.
- **YOU UNDERSTAND** the features of the chair and how they might be used to benefit particular users.
- **PLEASE ENSURE YOU READ** the basic technical checks. If you have purchased either of the Accupak or 20 cycle rechargeable battery systems, as an optional extra, please ensure you read the relevant instructions carefully.
- **YOU UNDERSTAND** the recommended user weight limit for your chair. It will be dependent on the Repose chair model that you have chosen. Please ensure that you understand these limits and **DO NOT** exceed them. This may damage the chair and **will invalidate your warranty**.
- **YOU CHECK** the chair and cables regularly to ensure that they are in a suitable working condition and that there is no damage. **DO NOT USE** the chair if it is not working properly or damaged.
- **YOU ALWAYS** move the chair around using the front of the arms and that you are mindful of your own physical attributes as you carry out any such movements. **DO NOT** use other parts of the chair to move it around as this may cause damage to the framework and workings of the chair and **will invalidate your warranty**. The chair **SHOULD NOT** be occupied when it is being moved around - **IT IS NOT** a portering chair.
- **YOU ALWAYS** take the necessary precautions and advice when carrying out any movement or handling operations.
- When using the functionality of the chair whilst someone is seated **ALWAYS** ensure that any movements are smooth and comfortable for the user to avoid any distress.
- Children **DO NOT** play with, or on, the chair as this may cause damage and could result in personal injury.

- **NO ONE** stands or sits on the arms or the leg rest as this may damage the chair and/or cause it to tip. To do so may cause personal injury.
- **NO ONE** stands on the seat as this may cause the chair to tip and/or damage the chair. To do so may cause personal injury.
- You are **ALWAYS** careful to keep hands, other body parts and clothes away from the moving parts of the mechanism when checking or during usage to avoid them being trapped.
- **YOU NEVER** exit the chair whilst the leg rest is elevated.
- If making transfers from any healthcare chair using a hoist / sling **ALWAYS** ensure that you have locking castors and that they are engaged to aid chair stability.
- The chair is **ONLY OPERATED AT NORMAL ROOM TEMPERATURES** and is **NEVER** used or stored in a damp or wet area.
- **YOU ALWAYS** store your handset in the pocket on the side of the chair or on the carer loop on the back of the chair, if you have purchased this option. This will ensure that it will not be damaged by either falling on the floor or from anyone sitting on it.
- Children **DO NOT** play with the handset. To do so may result in personal injury.
- **YOU ALWAYS** disconnect the power supply before checking any part of the chair.
- **NO** cables are trapped under the chair and that **YOU DO NOT** run over the cables with the castors or other equipment e.g. vacuum cleaner.
- If there is a spillage on the chair **IMMEDIATELY DISCONNECT THE ELECTRICITY FROM THE MAINS** and check that no electrical components are wet. If in any doubt please consult with your supplier or a qualified and authorised chair engineer.

Maintenance and repairs

- **YOU ONLY USE** approved parts on your chair. These can be obtained through your supplier. Failure to use approved parts **will invalidate your warranty.**
- **YOU ALWAYS** get your supplier or an authorised chair engineer to carry out any repairs or fit new parts to the chair. **DO NOT** attempt to carry out your own repairs to the chair as this may invalidate your warranty.
- **YOU NEVER MAKE** any material design, mechanical or other modifications to the chair as this may affect the way in which the chair operates and the inherent safety features. **It will also invalidate your warranty.**
- **YOU PROVIDE** your original purchase invoice and unique chair batch number when ordering parts or when making a claim under your warranty.

Accupak Rechargeable Battery System (Optional Accessory)

The Haven comes with the option of purchasing an Accupak rechargeable battery system for mains free usage.



Components received on delivery/Set up

- **The Accupak battery** will be fitted out of sight on the base of the chair and the charging outlet built into the side of the chair for ease of access.
- **The Transformer and power cables** which enable the battery to be initially charged / recharged will normally be connected to the chair when it is initially set up.
- **The handset user instructions** which can be found on page 14.
- **Only use the equipment supplied with the Accupak.**

Operation and charging

- When the chair is received the battery **MUST BE FULLY CHARGED** before usage. It is recommended that the battery is **CHARGED FOR AT LEAST 8 HOURS.**
- The battery **SHOULD BE OPERATED** at normal room temperatures and never in damp environments.
- The battery provides an average of up to 100 adjustment cycles.
- The plug-in **CONNECTIONS ARE ACCESSIBLE** so that the system can be switched off in an emergency.
- The Transformer must **ALWAYS** lie flat on the floor.
- The Accupak has an audible acoustic warning signal which is activated when the handset controls are used and the battery is low and requires recharging. The system still remains activated and emergency adjustment is possible, but please charge immediately. The battery also has an overall switch off threshold should you continue to operate the chair when the acoustic warning is sounding. This prevents deep discharge of the battery and permanent damage to it.
- **DO NOT** let the battery completely discharge as this will stop it from being fully charged again. If the battery is left to completely discharge it may have to be replaced and this is **not covered under the warranty.**
- It is **RECOMMENDED** that the battery is charged regularly overnight to prevent complete discharge.
- The chair may be used and operated whilst it is being charged, but **DO NOT** move the chair about when it is plugged in.
- The electrical components are designed to be used for no longer than 2 minutes continuous movement in any period of 20 minutes. (See Usage time on page 15).
- Rechargeable batteries, by their nature, have limited lifespans and are characterised by gradual power loss over time. This normal depreciation and continual power loss is **not covered under the warranty.**

Maintenance and disposal

- The rechargeable battery system is designed to be maintenance free.
- **DO NOT** open the Accupak. Check the cables and connections regularly for any signs of damage.
- **DO NOT** operate the system if there is any damage or if the unit gets too hot.
- **MAKE SURE** that the Accupak is kept clean and dry at all times.
- **DO NOT** submerge in water or expose to direct heat.
- **NEVER** run anything over the cables e.g. a Hoover, as this may damage them.
- **ALWAYS** store the chair in a dry and safe place which will protect the chair and the Accupak battery. If you are storing for periods of more than 6 months then the Accupak battery must be fully charged before being stored. The battery should be re-charged every 12 months when in storage.
- If your battery shows any signs of leakage do not allow the fluid to come into contact with your skin. If it does, clean the affected area and contact your doctor.
- **ONLY** clean the Accupak and battery transformer by wiping carefully with a slightly damp cloth. Do not use solvents or chemical cleaning agents, to clean them. **ALWAYS DISCONNECT the power source when doing any cleaning.**
- All batteries must be disposed of immediately if they are damaged. Batteries should always be disposed of in line with environmental regulations.

Basic Fault and Error Detection

Below we have listed some basic checks you can carry out if the chair mechanism stops working. If the chair is still not working after carrying out these steps we recommend that you contact your supplier or an authorised chair engineer.

Problem	Possible Cause	Remedy
Handset or mechanism movement not working (mains power disconnected from chair)	<ol style="list-style-type: none"> 1) No supply voltage 2) Deep discharge protection triggered (see above) 3) Handset or system defective 	<ul style="list-style-type: none"> • Connect chair to the mains/ charge the battery • If connecting to the mains /charging the battery does not work, contact supplier/ engineer
Handset or mechanism movement not working (mains power connected to chair)	<ol style="list-style-type: none"> 1) Thermoswitch has been triggered in transformer (you cannot see this), preventing the chair from being powered and the battery from charging 2) Handset or system defective 	<ul style="list-style-type: none"> • Leave the chair in a state of rest for 20 to 30 minutes • If leaving the chair at rest does not work, contact supplier / engineer
Acoustic Warning Sound can be heard	<ol style="list-style-type: none"> 1) The battery charge is very low (see above) 	<ul style="list-style-type: none"> • Immediately recharge the battery.

20 Cycle Rechargeable Battery System (Optional Extra)

The Haven comes with the option of purchasing a 20 Cycle rechargeable battery system for mains free usage.

Operation and charging

- When the chair is received the battery **MUST BE FULLY CHARGED** before usage. It is recommended that the battery is **CHARGED FOR AT LEAST 8 HOURS**. The green LED light on the charger will turn green when charging is complete.
- The battery **SHOULD BE OPERATED** at normal room temperatures and never in damp environments.
- The battery provides an average of up to 20 chair adjustments.
- There is an acoustic warning signal, a 5 second beep, that notifies you of a low remaining charge during operation. Charge the battery before further use.
- **DO NOT** let the battery completely discharge as this will stop it from being fully charged again. If the battery is left to completely discharge it may have to be replaced and **this is not covered under the warranty**.
- It is **RECOMMENDED** that the battery is charged regularly overnight to prevent complete discharge.
- The chair may be used and operated whilst it is being charged, but **DO NOT** move the chair about when it is plugged in.
- The electrical components are designed to be used for no longer than 2 minutes continuous movement in any period of 20 minutes. (See Usage time on page 15).
- Rechargeable batteries, by their nature, have limited lifespan and are characterised by gradual power loss over time. This normal depreciation and continual power loss **is not covered under the warranty**.

Maintenance and disposal

- The rechargeable battery system is designed to be maintenance free.
- **DO NOT** open the battery.
- If your battery shows any signs of leakage do not allow the fluid to come into contact with your skin. If it does, clean the affected area and contact your doctor.
- If the battery is stored disconnect the battery from the control or drive system and ensure you charge it every six months. Maximum storage time is 12 months.
- **ONLY** use a dry cloth to clean.
- Damaged batteries must be disposed of immediately and in line with environmental regulations.

Repose always recommend that a qualified chair engineer carries out any checks.

Basic Technical Checks

If the chair stops working and you have purchased either an Accupak or a 20 Cycle battery system please refer to pages 8, 9 and 10. If you do not have either system then some simple checks you might carry out are:

- **CHECK** the handset is not damaged.

If this is okay then check the following, but **ALWAYS DISCONNECT** your chair from the power source when doing the following checks.

- **CHECK** the wall socket is in working order by trying another appliance.
- **CHECK** to see if any cable connections have become disconnected.
- **CHECK** to see if any of the cables are damaged or trapped. Damaged cables should be changed.
- **DO NOT** open or attempt to open any electrical components. **To do so may invalidate your warranty.**

If the chair is still not working then you should contact an authorised chair engineer or your supplier and ask them to check the chair thoroughly.

Recommended Quality Checks

The chair should always be checked every time it is used for signs of damage or excessive wear and tear to ensure safe and reliable usage is maintained. Regular checks should include, but are not limited to:

- Damage to the cables.
- Any loose or detached parts.
- Damage to the handset.
- Damage to the fabric of the chair.
- Castors for damage or any build up of fluff, dirt or dust particles.

Chair Delivery

The chair will have been set up at the date of delivery and supplied with a full set of documents. If you have any questions please speak to the person or company that took delivery.

Pressure Care Management

The Haven has been designed to incorporate a number of pressure management features. The use of these features will depend on your assessment of the client's requirements.

Please ensure that you understand the features and how they can be used.

For the benefit of your client we always recommend that those setting up or operating the Haven are trained on the use of the chair and in pressure management and postural care.

Weight Limits

The Haven has a weight limit of 95 Kg (15 stone) as standard on the small model. On the medium and large the weight limit can be up to 127 Kg (20 stone). The maximum leg rest weight limit is 57 kg (9 stone) on all models.

If you are in any doubt about any of the options please ask your supplier.

Feature Functionality

Below we have detailed the chair's key functionality which will enable full usage of the chair allowing you to provide additional comfort and posture control for the user. Please read the User Manual for complete details on how to operate your model of chair.

Chair location

It is essential that you locate the chair correctly so as to ensure that all of the features will work properly:

- Position the chair in your chosen location, ensuring that there is enough space to recline fully and freely. There should be no objects behind the chair that could obstruct its movement. The chair should never touch the wall when it reclines.
- The leg rest should be able to move fully and freely with no objects to restrict this movement.
- Position the chair free from any trailing wires.
- Ensure that the chair is within easy reach of a power point to charge or recharge the battery system.
- Always ensure that there is enough space for the carer to operate the chair.

Important note – Obstructions may cause damage to the chair and its mechanism **and will invalidate your warranty.**

Durable Castors

The Haven comes with durable castors built in as standard. There is the option to upgrade to either lockable castors or glides which are suitable for wooden or laminated floors.

Important note – If you choose the lockable castors please note that this will increase the seat height by 25mm (1").



Handset instructions

The Haven has the option of two different Tilt in Space mechanisms each one having its own handset. Please ensure you follow the handset instructions for your mechanism.

If you have purchased the optional handset loop on the back of the chair please ensure that the handset is hooked on to it or stored in the side pocket to avoid damage.

Single Tilt in Space Handset

The Single Tilt in Space (STIS) mechanism comes with a simple to use, two button handset which operates the Tilt in Space movement. The following instructions will aid easy use of your chair.

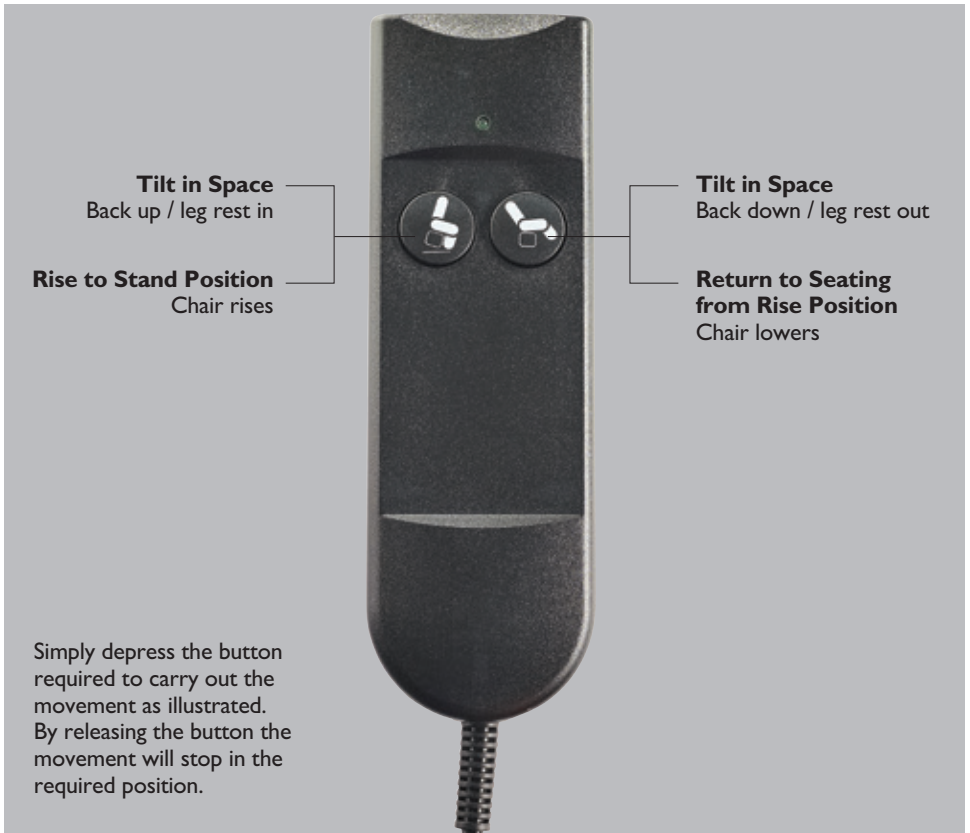

Dual Tilt in Space Handset

This mechanism is operated by an easy to use four button handset. The following instructions will aid use of your chair. Simply depress and release the desired button to reach the correct position as indicated on your handset.

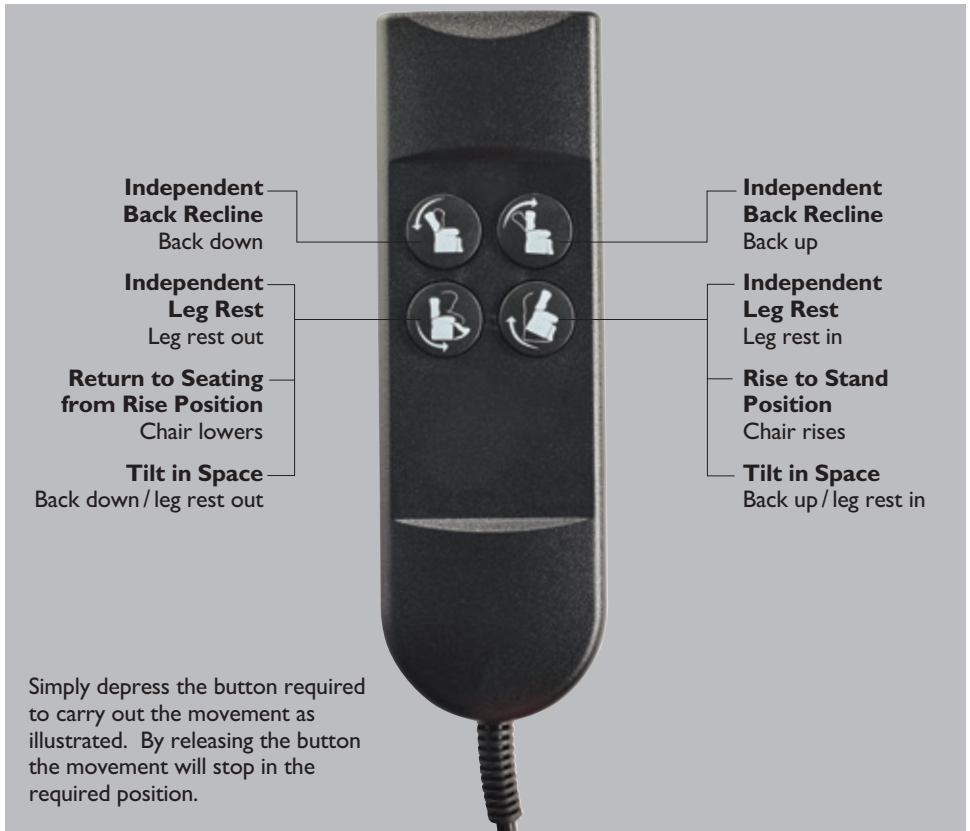

Electric components - Usage time

The electrical components are designed to be used for no more than 2 minutes continuous movement in any period of 20 minutes. If they are used for 2 minutes continuously then they should not be used for another 18 minutes. Two minutes will allow for considerable amount of movements in line with normal operation.

Single Tilt in Space (STIS) adjustment

The two button handset allows you to tilt the chair gently in a range of positions or to raise the seat to aid standing. The Tilt in Space function allows the seat-to-back angle to remain the same whilst the whole seating system is tilted backwards. This ensures that the angle of the hips, knees and ankles remain unaffected and the weight on the Ischial Tuberosities is reduced by redistributing the weight through the back. This constant angle also prevents shearing to the back and the bottom during movement.



Full Rise



Static Position



Semi Recline



Footrest Horizontal



Fully Recline

Dual Tilt in Space (DTIS) adjustment

As well as the Tilt in Space function, described above, this mechanism also features an independent backrest recline and independent leg rest movement, all controlled by the easy to use four button handset.



Full Rise



Static Position



Independent Back Rest



Semi Recline

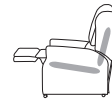

Footrest Horizontal



Fully Reclined



Healthcare considerations for Single and Dual Tilt in Space Mechanisms

Tilt in Space mechanisms provide key advantages to support the care of individuals:

- Can be specified as part of a 24-hour postural management programme with a wide range of positions.
- Ideal for those who are unable to independently manoeuvre their weight to relieve pressure build up.
- Assisted movement reduces the risk of skin breakdown due to poor skin integrity, high pressure risk or poor circulation.
- Can support people with swallowing problems by allowing them to position themselves optimally for food to be swallowed, for example, individuals with neurological conditions such as MND.
- Can also be very useful for those with low blood pressure enabling carers to alter their position to reduce the impact of changes in pressure e.g. postural hypotension.



Seat Chaise and cover

The Haven benefits from a single, full seat cover and chaise. This chaise removes any pinch points and reduces the risk of pressure areas developing because of them. It also provides deep comfort to all parts of the body in contact with the chair. The chaise cover and memory foam are removable.

To remove firstly take off the back cushion. Then at the back of the seat cushion release the chaise from the Velcro and peel off the chaise. The chaise is also secured by Velcro to the front of the seat and under the footplate, again simply peel off.

Back Cushion Features

The Haven comes with a split contoured back which comes as two separate cushions:

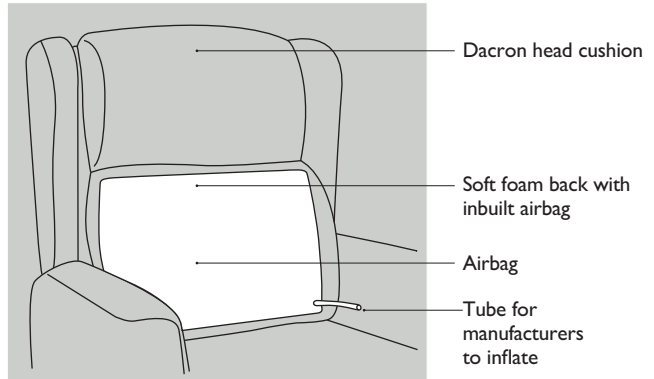

A top head cushion

This is filled with Dacron fibres and has adjustable padding levels through the addition or removal of fibres. The cover is removable for cleaning or replacement. It can also be positioned on the back frame, as required, using the Velcro.



A lower back cushion

This supports the thoracic and lumbar part of the back through a one cell air bag surrounded by a soft foam surface. The air in the bag is pre-set at the manufacturers, but can be also altered by a trained care professional using the air valve and pump. Simply remove the back from the Velcro strips on the back frame to adjust.



Air cushion location

The air cushion and cover can be removed using the zip. The pump is easy to use and can be found at the base of the back (see below). The air level on the cushion is pre-set before despatch.



Zip for removal of air cushion / cover.

Pump at the base of the back.

Inflation and deflation of the air cushion

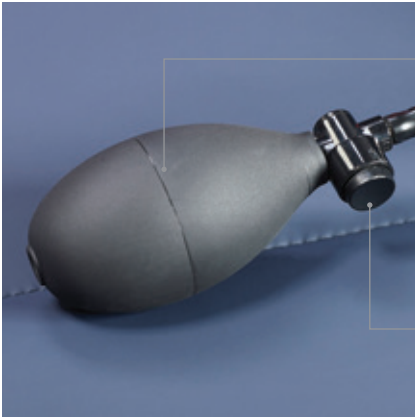

To pump up the cushion simply squeeze the pump until the desired firmness is achieved.

To release air from the cushion simply press the black button as indicated which will let air out so that the desired firmness is achieved.

Seat and Leg Rest Cushion Features

The Haven comes with a combined seat cushion and chaise with single air bags for additional pressure management in both the seat and leg rest cushions. For the seat cushion we recommend a fabric with four way stretch properties to aid the reduction of friction and shear.

Single air seat cushion

For those who currently have or who are at a high risk of pressure problems or sores and who have limited ability to change their position and relieve the pressure on their sacrum and buttocks.

Users need to have good pelvic stability and core trunk strength to accommodate the air pressure changes and related movement in this single air cushion.

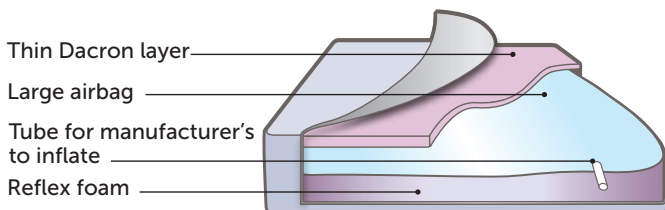

Pressure Risk **MEDIUM** **HIGH**

Leg rest air cushion

The single cell airbag provides consistent support across the whole of the thighs, back of the knees and calf and reduces the risk of pressure problems.

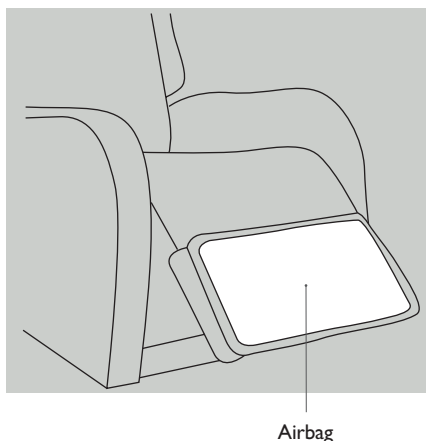

Seat / Leg rest cushion and cover removal

The seat cushion and chaise can be removed as one. To remove firstly take off the back cushion. Then at the back of the seat cushion release the chaise from the Velcro and peel off the seat cushion and chaise. The chaise is also secured by Velcro to the front of the seat and under the leg rest, again simply peel off.

The cover and cushions can be removed for replacement or cleaning.



Air cushion location

The air levels on the cushions are pre-set before despatch. They can be adjusted using the air pump. On the seat cushion this is found at the back of the seat cushion (attached to the base of the cushion) and on the leg rest on a clip at the back of the footrest.

Inflation and deflation of air cushions



To pump up the cushion simply squeeze the pump until the desired firmness is achieved.

To release air from the cushion simply press the black button as indicated which will let air out so that the desired firmness is achieved.

Optional Accessories

The following accessories are optional on the Haven:

- Coolform gel in arm covers
- Handset loop on back of chair for carer
- Pocket moved to the left-hand side
- Lockable castors
- Glides for use on laminated and wooden floors
- Back and seat cushion replacement

High wear protection covers all in matching fabrics:

Full length arm cover/head cover/seat cover

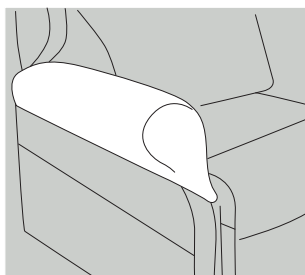

Full length arm cover

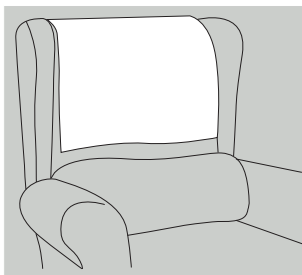

Head cover

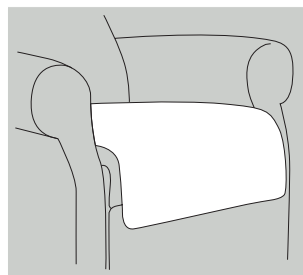

Seat cover

A range of headrests that include:

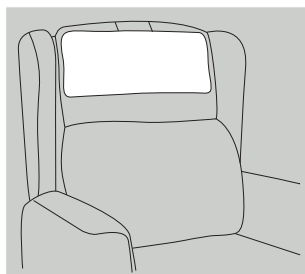

Small head pillow

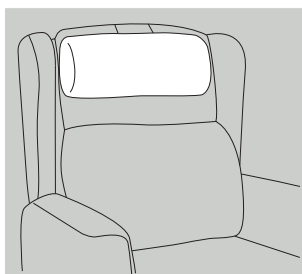

Head roll

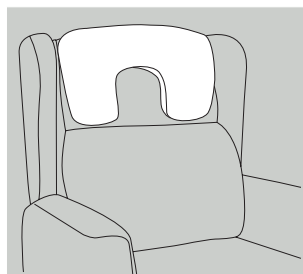

Small profile headrest

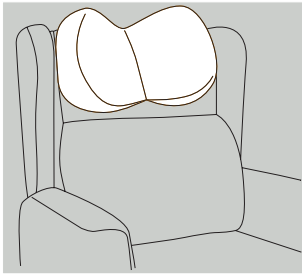

Midline Headrest

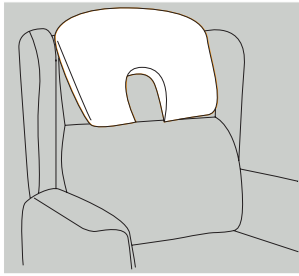

Large Profile Headrest

Safety options

- 20 cycle back-up unit
- Accupack rechargeable battery system for mains free usage
- Enclosure skirt

Chair Dimensions

The Haven has a weight limit of 95 Kg (15 stone) as standard on the small model. On the medium and large models the weight limit can be up to 127 Kg (20 stone).



	Small	Medium	Large
Seat Height	432mm (17")*	483mm (19")*	533mm (21")
Seat Width	457mm (18")	508mm (20")	559mm (22")
Seat Depth	457mm (18")	508mm (20")	508mm (20")

* Please note that the seat, back and arm heights may change slightly due to submersion in the air seat cushion. In addition, if you select the lockable castors, the seat height will be raised by 25mm (1").

Standard Back Height:

711mm / 737mm (28" / 29")*

Standard Arm Height:

178mm (7")*

Fabrics

All our healthcare fabrics are Waterproof, Anti-MRSA, Anti-bacterial, Anti-fungal, Crib 5 and bleach cleanable and all cushions and cushion covers are removable for cleaning purposes. For our full range of health fabrics and cleaning instructions please visit our website.



General Upholstery Care

The Haven comes with an extensive range of fabric options. **Always** ensure that you follow the cleaning instructions for **your particular upholstery**. You will find details of all of the fabrics on our web site along with their respective cleaning instructions. Please note that different fabrics will have different characteristics and cleaning instructions, **ask your supplier if you are in any doubt** about the cleaning instructions. Repose cannot be held responsible for any damage caused by cleaning.

Some general care tips:

- **Regular cleaning** is required to maintain the appearance and cleanliness of your chair. Small dust and dirt particles can increase the wear and tear of the upholstery and may dull the fabric.
- Your **upholstery should not be exposed** to direct sunlight for long periods of time as this will cause your fabric to fade. If your furniture is positioned within prolonged light, ensure your curtains and blinds are drawn for protection.
- **Ensure** your upholstery is protected from sharp objects or buckles as these may cause the fabric and/or upholstery to snag or become damaged.
- **Avoid** allowing pets onto your furniture as their claws may cause damage to the fabric and upholstery. All animals have a degree of oil in their coats which may transfer to your fabric if they go onto the chair. This will cause your fabric to wear prematurely.
- If you have fibre filled cushions regularly plump to avoid the fibres flattening.

Important note:

The person cleaning the chair **should always** use protective gloves to reduce the risk of infection transmission.

Transport- Attach / Remove Back Frame

For ease of transport the back frame can be separated from the seat base. The back frame attaches to the seat base by inserting the housing pins on the seat frame into the brackets on the side of the chair back frame (see below).

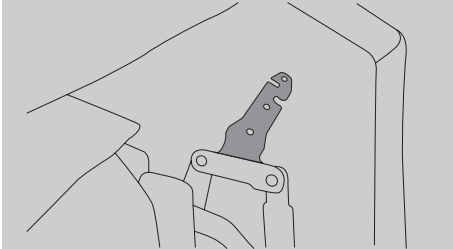

Housing pins on back frame.

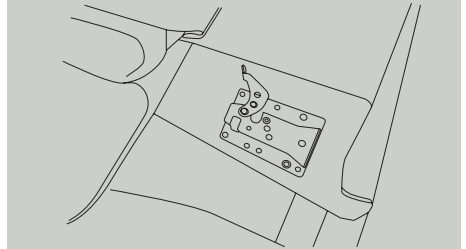

Housing bracket on side of seat frame.

Steps involved in attaching the back frame:

Step 1

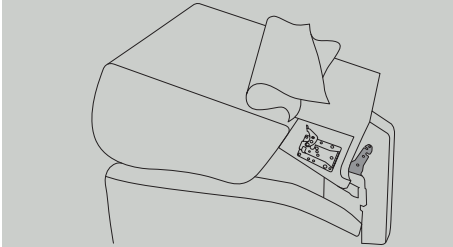

Firstly lie the back on top of the base with the top facing forward.

Step 2

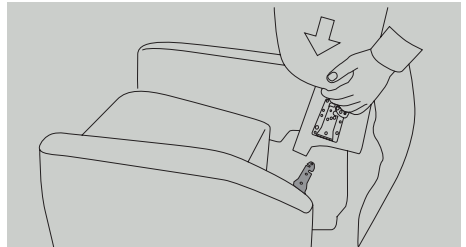

Lift the back and position the brackets over the housing pins.

Step 3

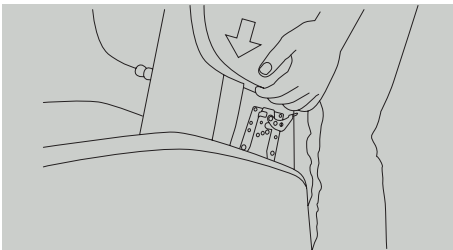

Slide the brackets onto the housing pins and gently apply pressure to the top of the back and push down to ensure it is securely in place.

Step 4 (Locking)

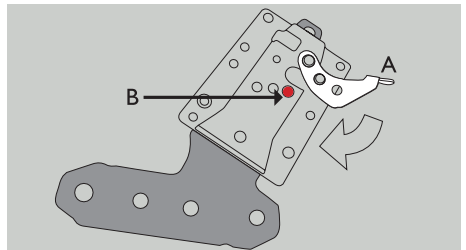

Then lock the back into position - push down on the swing tab (A) on the housing bracket until it locks into position over the chrome button (B).

Warranty

Two years on mechanisms, frame and upholstery. One year on air seat cushions.

Repose will repair or replace, at our discretion and free of charge to the original purchaser, any parts covered by this warranty and which on examination, are found to be defective in material and/or workmanship. The warranty is for parts and labour only and for transportation to and from the original delivery point. It does not include any white glove delivery service. If this is required it will incur an additional cost.

Warranty Exclusions

- Fabric damage resulting from misuse, negligence, abuse, accident or incorrect cleaning
- Unauthorised or incorrect repairs, alterations and modifications
- Damage to the chair from misuse, negligence, abuse or accident
- Damage caused from normal wear and tear
- Damage caused by common carrier abuse or mishandling and any special, indirect, incidental and/or consequential damages
- Replacement of the battery if the battery is left to completely discharge.

Statutory Rights

Nothing contained in our Terms and Conditions nor in these guidelines shall effect the statutory rights of the customer.

Warranty Claim

Please contact your supplier with your original purchase invoice and unique chair batch number and they will make the necessary arrangements with Repose. The batch number and supplier details can be found under the base of the leg rest near to the end. Simply elevate the leg rest to view.

Batch Label



Batch Number:

Supplier:



Specialist Seating Solutions

Repose Furniture Limited, Attwood House
Cokeland Place, Cradley Heath, West Midlands
B64 6AN

Tel: 0844 7766 001*

Fax: 0844 7766 002*

Email: service@reposefurniture.co.uk

*Calls cost 7p per minute plus your networks access charge

Visit our web site for more details
www.reposefurniture.co.uk

